



Table of contents

Warning	2
Safety Instructions	2
Operating Determinations	3
Connection with the mains.....	3
Return Procedure.....	4
Claims.....	4
Description of the device	5
Frontside.....	5
Installation	6
Inserting/ Replacing the battery.....	6
Testing a cable.....	7
Connection Cables	8
Maintenance	9
Replacing the Fuse.....	9
Product Specifications	10
Dimensions	11
Notes	12

Warning



**For your own safety, please read this user manual carefully
before your initial start-up!**



Unpacking Instructions

Immediately upon receiving this product, carefully unpack the carton and check the contents to ensure that all parts are present, and have been received in good condition. Notify the dealer immediately and retain packing material for inspection if any parts appear damaged from shipping or the carton itself shows signs of mishandling. Save the carton and all packing materials. In the event that a fixture must be returned to the factory, it is important that the fixture be returned in the original factory box and packing.

Your shipment includes:

- DAP Audio Cable Tester Pro
- User manual



CAUTION!
Keep this device away from rain and moisture!
Unplug mains lead before opening the housing!



Safety Instructions

Every person involved with the installation, operation and maintenance of this system has to:

- be qualified
- follow the instructions of this manual



CAUTION! Be careful with your operations.
**With a dangerous voltage you can suffer
a dangerous electric shock when touching the wires!**



Before your initial start-up, please make sure that there is no damage caused by transportation. Should there be any, consult your dealer and do not use the system.

To maintain perfect condition and to ensure a safe operation, it is absolutely necessary for the user to follow the safety instructions and warning notes written in this manual.

Please consider that damages caused by manual modifications to the system are not subject to warranty.

This system contains no user-serviceable parts. Refer servicing to qualified technicians only.

IMPORTANT:

The manufacturer will not accept liability for any resulting damages caused by the non-observance of this manual or any unauthorized modification to the system.

- Batteries are hazardous waste which need to be disposed properly. If the device has to be disposed, remove the battery first.
- Make sure to connect the poles of the battery correctly.
- Never leave batteries lying around openly as there is the danger that these can be swallowed by children or domestic animals. Immediately consult a doctor when batteries are swallowed!
- Leaking or damaged batteries can cause irritation when getting into contact with the skin. In case of leaking batteries use appropriate protecting gloves for removing them.
- Make sure the battery cannot be short-circuited, thrown into fire. Do not attempt to charge the battery. In these cases, there is the danger of explosion.
- Never spill any liquids on the device. Should any liquid enter the device, remove the battery immediately. Let the device check by a qualified technician before you operate it again. Any damages caused by liquids having entered the device are not subject to warranty.
- Never remove warning or informative labels from the unit.
- Never leave any cables lying around.
- Do not connect this system to a dimmer pack.
- Do not open the device and do not modify the device.
- Do not shake the device. Avoid brute force when operating the device.
- Only use device indoors, avoid contact with water or other liquids.
- Avoid flames and do not put close to flammable liquids or gases.
- If device is dropped or struck, disconnect mains power supply immediately. Have a qualified engineer inspect for safety before operating.
- If the system has been exposed to drastic temperature fluctuation (e.g. after transportation), do not switch it on immediately. The arising condensation water might damage your system. Leave the system switched off until it has reached room temperature.
- If your DAP Audio device fails to work properly, discontinue use immediately. Pack the unit securely (preferably in the original packing material), and return it to your DAP Audio dealer for service.
- Make sure that the available voltage is not higher than stated on the rear panel.
- Make sure you do not use the wrong kind of cables or defective cables.
- Repairs, servicing and electric connection must be carried out by a qualified technician.
- For replacement use fuses of same type and rating only.
- WARRANTY: Till one year after date of purchase.

Operating Determinations

This system is not designed for permanent operation. Consistent operation breaks will ensure that the system will serve you for a long time without defects.

If this system is operated in any other way, than the one described in this manual, the product may suffer damages and the warranty becomes void.

Any other operation may lead to dangers like short-circuit, burns, electric shock, etc.

You endanger your own safety and the safety of others !

Improper installation can cause serious injuries to people and/or damage of property !

Connection with the mains

Connect the device to the mains with the power-plug.

Always pay attention, that the right color cable is connected to the right place.

International	EU Cable	UK Cable	US Cable	Pin
L	BROWN	RED	YELLOW/COPPER	FASE
N	BLUE	BLACK	SILVER	NULL
	YELLOW/GREEN	GREEN	GREEN	EARTH

Make sure that the device is always connected properly to the earth!

Improper installation can cause serious injuries to people and/or damage of property !



Return Procedure



Returned merchandise must be sent prepaid and in the original packing, call tags will not be issued. Package must be clearly labeled with a Return Authorization Number (RMA number). Products returned without an RMA number will be refused. Highlite will not accept the returned goods or any responsibility. Call Highlite 0031-455667723 or mail aftersales@highlite.com and request an RMA prior to shipping the fixture. Be prepared to provide the model number, serial number and a brief description of the cause for the return. Be sure to properly pack fixture, any shipping damage resulting from inadequate packaging is the customer's responsibility. Highlite reserves the right to use its own discretion to repair or replace product(s). As a suggestion, proper UPS packing or double-boxing is always a safe method to use.

Note: If you are given an RMA number, please include the following information on a piece of paper inside the box:

- 01) Your name
- 02) Your address
- 03) Your phone number
- 04) A brief description of the symptoms

Claims

The client has the obligation to check the delivered goods immediately upon delivery for any shortcomings and/or visible defects, or perform this check after our announcement that the goods are at their disposal. Damage incurred in shipping is the responsibility of the shipper; therefore the damage must be reported to the carrier upon receipt of merchandise.

It is the customer's responsibility to notify and submit claims with the shipper in the event that a fixture is damaged due to shipping. Transportation damage has to be reported to us within one day after receipt of the delivery.

Any return shipment has to be made post-paid at all times. Return shipments must be accompanied with a letter defining the reason for return shipment. Non-prepaid return shipments will be refused, unless otherwise agreed in writing.

Complaints against us must be made known in writing or by fax within 10 working days after receipt of the invoice. After this period complaints will not be handled anymore.

Complaints will only then be considered if the client has so far complied with all parts of the agreement, regardless of the agreement of which the obligation is resulting.

Description of the device

Features

The Cable Tester pro is your ideal tool for checking all your audio cables. It is easy in use and rugged enough for use on the road.

- Must have for every roady
- 9V Battery operated
- Speakon 4P, Speakon 8P, RJ45, RCA
- XLR 3P, XLR 5P, 5P Din, 6,3 Jack, 3,5 Jack
- Test function for:
 - Speakerplug 4 pole
 - Speakerplug 8 pole
 - RJ-45
 - 3,5 Mini-Jack
 - 6,3 Jack
 - XLR 5 pole
 - XLR 3 pole
 - RCA
 - 5 pole Din
- Dimensions: 187 x 37 x 90mm

Frontside

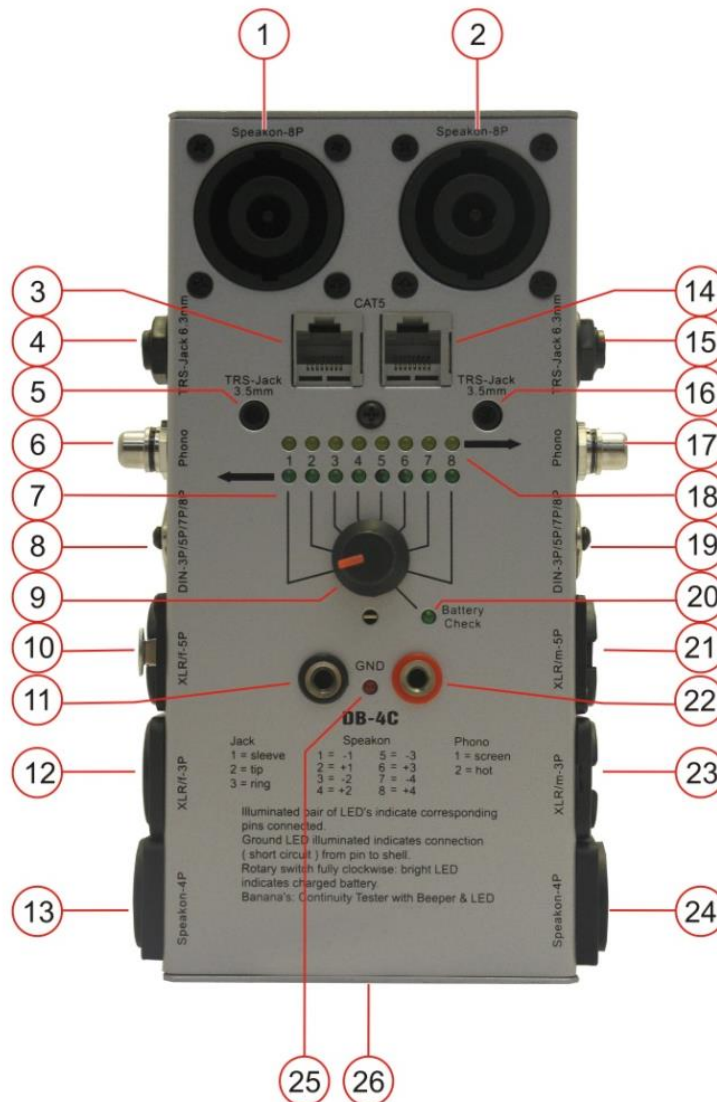

- 01) Speakon-8P Socket
- 02) Speakon-8P Socket
- 03) Cat 5- Socket
- 04) TRS-Jack 3,5 mm Socket
- 05) TRS-Jack 6,3 mm Socket
- 06) Phono (RCA) - Socket
- 07) Contact 1-8 indication LED
- 08) Din- 3P / 5P / 7P / 8P-aansluiting
- 09) Contact Selector
- 10) XLR / F-5P-connector
- 11) Banana Socket
- 12) XLR / F-3P- Socket
- 13) Speakon-4P- Socket
- 14) Cat 5- Socket
- 15) TRS-jack 6,3 mm-Socket
- 16) TRS-jack 3,5 mm- Socket
- 17) Phono (RCA) – Socket
- 18) Contact 1-8 indication LED
- 19) Din- 3P / 5P / 7P / 8P- Socket
- 20) Battery Check LED
- 21) XLR / M-5P- Socket
- 22) Banana Socket
- 23) XLR / M-3P- Socket
- 24) Speakon-4P Socket
- 25) GND-LED
- 26) Battery Compartment

Installation

Remove all packing materials from the Cable Tester Pro. Check that all foam and plastic padding is removed. Connect all cables.

**Always disconnect from electric mains power supply before cleaning or servicing.
Damages caused by non-observance are not subject to warranty.**

Inserting/ Replacing the battery

Open the battery cover and remove it.

If replacing the battery, remove the old battery from the battery compartment. Leaky or damaged batteries might cause irritation to the skin. When handling them you should use protective gloves.

Insert the battery and make sure the poles are correct.

Close the battery cover.

If the device is not used for a longer period of time, remove the battery.



Fig. 01

Testing a cable

At first, turn the rotary switch fully clockwise to test the battery condition. The battery LED will light bright green if the internal battery is fully charged.

Then plug one end of the cable into the appropriate jack on the left side panel of the cable tester. Plug the other end of the cable into the appropriate jack on the right side panel. Set the rotary switch to "1" to test the connection of contact 1 on the plug inserted into the left side panel.

If there is a connection, the Green LED will light below "1" and a Yellow LED will light above each contact on the right side plug connected to "1" on the left side plug. Use the tables in appendix 1 to verify proper cable connections.

If no LED lights then there is no connection and the left side contact "1" is "floating" due to design or an "open" in the cable.

Set the rotary switch to "2" to test contact 2, and so on, until all contacts have been checked.

If the Ground LED lights then there is a connection between the corresponding contacts and the chassis.

To test the cable with a banana plug, just plug each end of the cable into the banana jacks. The LED will light and the unit will beep a tone if there is a connection between the plugs. These banana jacks can also be used for continuity tests using two probe leads.

Connection Cables

Take care of your cables, always holding them by the connectors and avoiding knots and twists when coiling them: This gives the advantage of increasing their life and reliability. Periodically check your cables. A great number of problems (faulty contacts, ground hum, discharges, etc.) are caused entirely by using unsuitable or faulty cables.

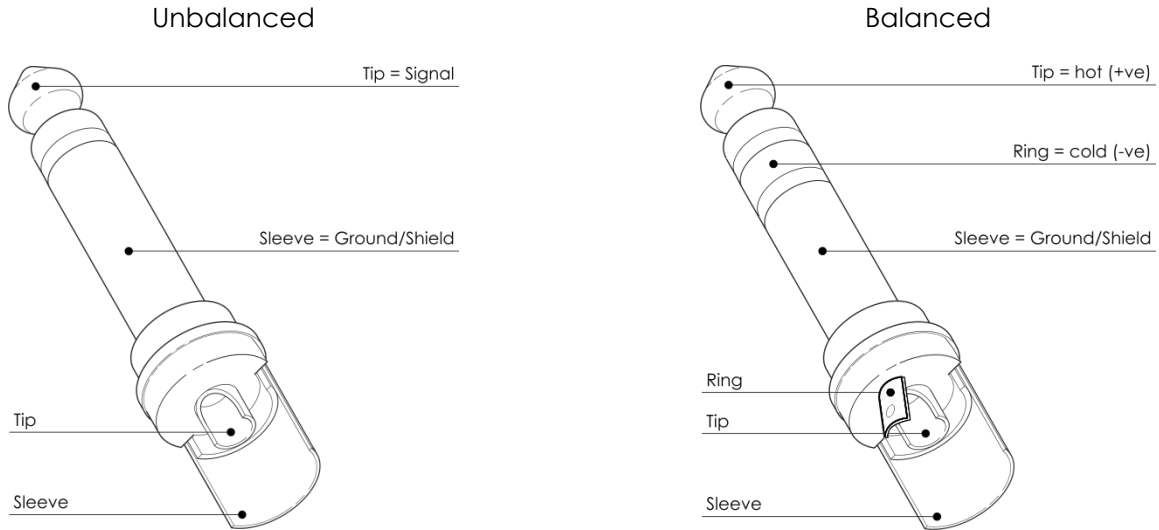

For these applications the unit provides 1/4" TRS and XLR connectors to easily interface with most professional audio devices. Follow the configuration examples below for your particular connection.

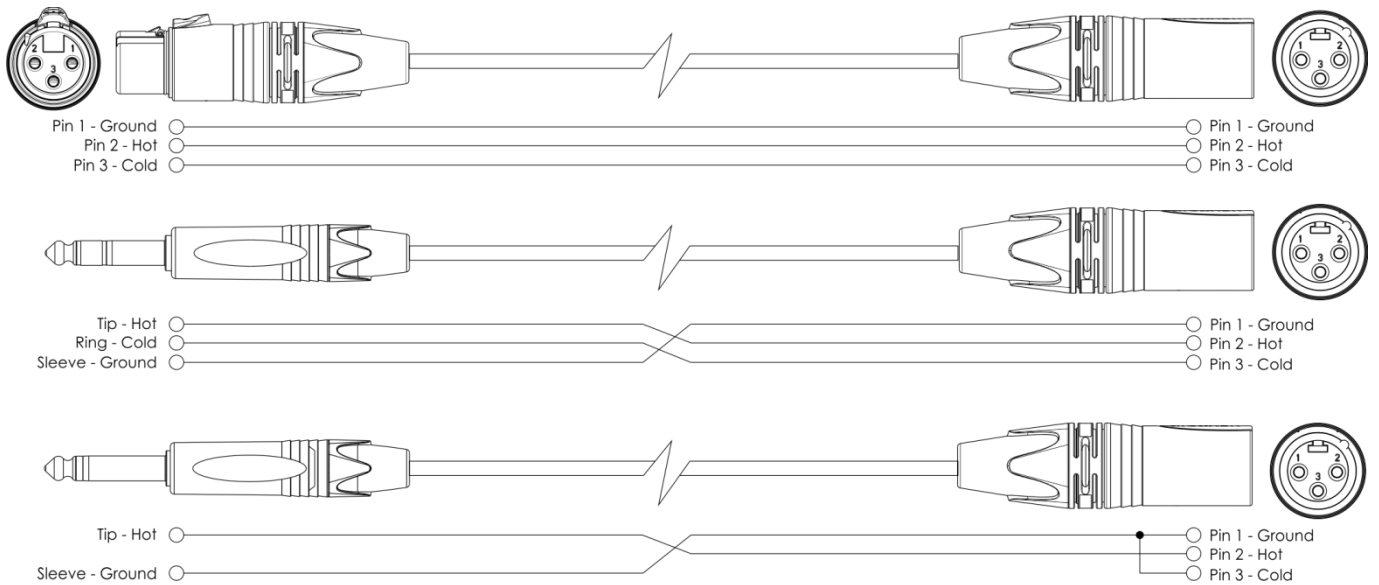

Maintenance

The DAP Audio Cable Tester Pro requires almost no maintenance.

However, you should keep the unit clean.

Disconnect the mains power supply, and then wipe the cover with a damp cloth. Do not immerse in liquid. Do not use alcohol or solvents.

Keep connections clean. Disconnect electric power, and then wipe the audio connections with a damp cloth. Make sure connections are thoroughly dry before linking equipment or supplying electric power.

Replacing the Fuse

Power surges, short-circuit or inappropriate electrical power supply may cause a fuse to burn out. If the fuse burns out, the product will not function whatsoever. If this happens, follow the directions below.

- 01)** If the device does not work properly, turn the device off.
- 02)** Check the battery.
- 03)** If all of the above appears to be O.K., switch the unit on again.
- 04)** If nothing happens after 30 seconds, switch the device off.
- 05)** Return the device to your DAP Audio dealer.

Product Specifications

Model: Cable Tester Pro

Electrical

Power: 1x standard 9V battery

Physical

Dimensions: 190 x 112 x 60 mm (LxWxH) incl. connectors

Weight: 0,8 kg

Design and product specifications are subject to change without prior notice.



Website: www.Dap-audio.info

Email: service@highlite.com

Dimensions





©2020 DAP Audio